

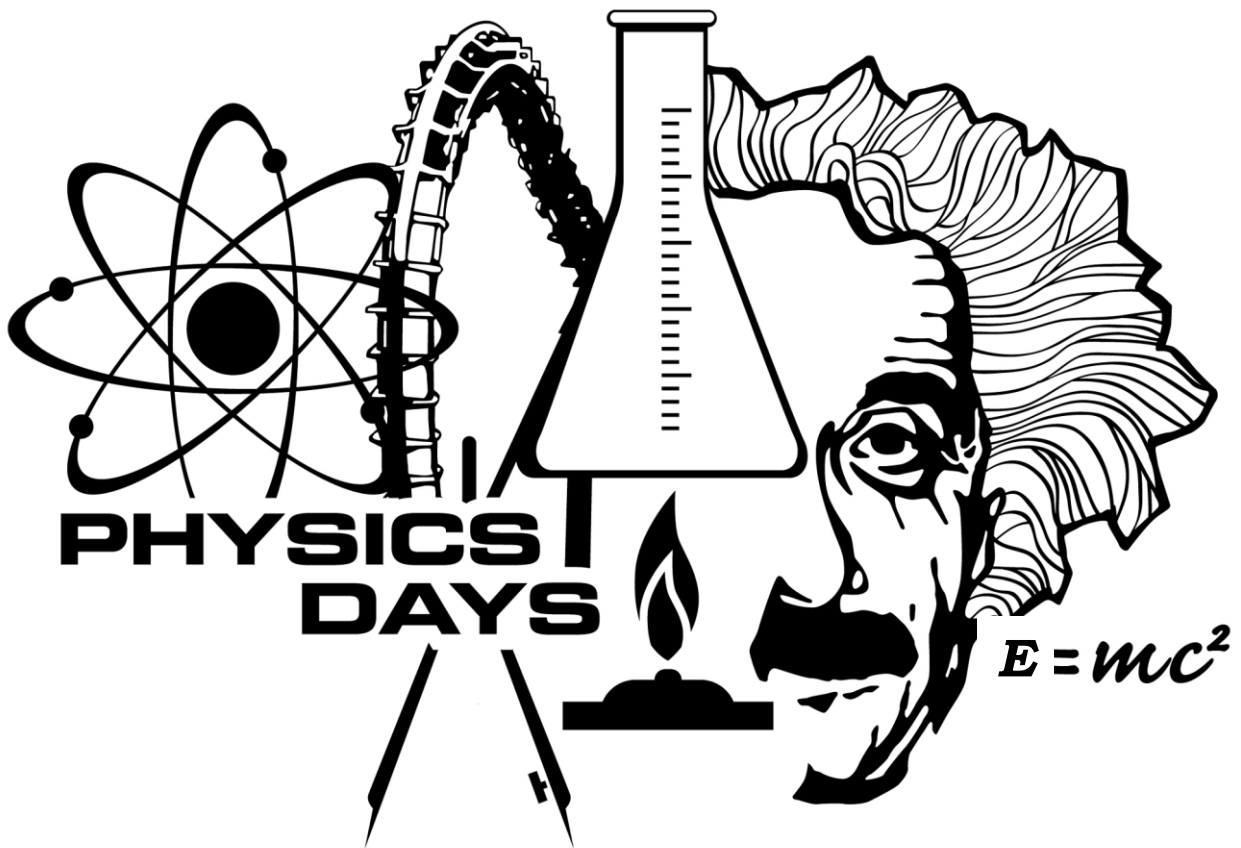

SixFlags[®]
GREAT AMERICA



STUDENT MANUAL

©2014 Six Flags Theme Parks authorizes individual teachers who use this book permission to make enough copies of material in it to satisfy the needs of their own students and classes. Copying of this book or parts for resale is expressly prohibited. We would appreciate being noted as the source, "Six Flags® Great America, Chicago" in all materials used based on this publication.

**Six Flags Great America
542 North Route 21
Gurnee, Illinois 60031**

847-249-1952

CONSCIOUS COMMUTING



As you ride to Six Flags Great America, be conscious of some of the PHYSICS on the way.

A. STARTING UP -- THINGS TO MEASURE:

As the bus pulls away from a stop sign, find the time it takes to go from rest to 20 miles per hour. *You will have to put someone up front to help.*

t = _____ seconds

THINGS TO CALCULATE: ALWAYS SHOW EQUATIONS USED AND SUBSTITUTIONS

1. Convert 20 miles per hour to meters per second. $V = \text{_____ m/s}$
(1.0 MPH = 0.44 meters/second)
2. Find the acceleration of the bus. $a = \text{_____ m/s}^2$
3. Using your mass in kilograms and Newton's Second Law, find the average forward force on you as the bus accelerates from rest.

$F = \text{_____ N}$

4. Is this force greater or less than the at rest force gravity exerts on you (your weight)?
5. Calculate the force factor that you felt.

force factor = $\frac{\text{force calculated (question 3)}}{\text{weight}} = \frac{\text{N}}{\text{N}} = \text{_____}$

(PLEASE NOTE: The force factor has no units.)

THINGS TO NOTICE AS YOU RIDE:

1. As you start up, which way do you FEEL thrown (forward or backward)?
2. If someone were watching from the side of the road, what would that person see happening to you in relation to the bus?
3. How can you explain the difference between what you feel as the bus starts up and what the observer sees? (You may want to use the ideas of FRAMES OF REFERENCE).

Conscious Commuting-Continued

B. GOING AT A CONSTANT SPEED - THINGS TO NOTICE

- 1. Describe the sensation of going at a constant speed. Do you feel as if you are moving?**
- 2. Are there any forces acting on you in the direction you are moving? Explain what is happening in terms of the Principle of Inertia.**

C. ROUNDING CURVES - THINGS TO NOTICE

- 1. If your eyes are closed:**
 - A. How can you tell when the bus is going around a curve?**
 - B. What do you feel when you are seated facing forward?**
 - C. What do you feel when you are seated with your back against the side of the bus?**
- 2. Before the bus starts around a curve, concentrate on a tree or a building that is directly in front of you. From the Law of Inertia, you know that your body should continue straight ahead unless an unbalanced force acts on it. See if you can sense the force that causes you to go around the curve.**
 - A. What is the direction of the force as you go through the curve?**
 - B. If the turn were tighter (smaller radius) how would the force be different?**
 - C. How is this force applied to your body? (A) the friction of the seat, (B) your seat mate, (C) the wall, (D) the arm of the seat or (E) a combination of these. Explain.**
- 3. Many of the rides in the amusement park involve going around curves. Be prepared to compare what you are feeling on the bus with sensations on the rides. Predict some differences you expect to feel.**

SENSING SENSATIONS & FORCE FACTORS

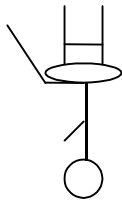
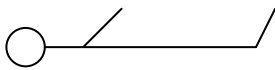
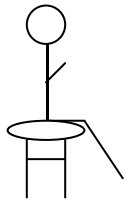

1. Here, you are in a chair. Show the size and direction of the force the chair is exerting you. On what part of your body is this force exerted?
2. Here, you are standing up. Show the size and direction of the force the ground is exerting on you. On what part of your body is the force exerted?
3. Here, you are lying on the ground. Show the size and direction of the force the ground is exerting on you.
4. Here, you are upside down and strapped into a chair. Show the size and direction of the force that keeps you from falling out. What is exerting this force and on what part of your body is it exerted?
5. Based on your answers to the previous questions, how could you tell what position you were in if your eyes were closed?

FORCE FACTOR:

A force factor enables you to express the size of a force you are experiencing as a multiple of your gravitational force (mg).

TO CALCULATE A FORCE FACTOR, divide the force being applied to a person or object by the normal (rest) weight of that person or object.

$$\text{Force factor} = \frac{\text{Force being applied}}{\text{Gravitational rest force}}$$

EXAMPLES OF HOW TO USE *FORCE FACTORS*

When you are experiencing a force factor:

EQUAL to 1, you feel **NORMAL**. **RIGHT NOW** you feel a force on your seat exactly equal to your weight as the seat supports you.

GREATER than 1, you **FEEL HEAVIER** than normal and feel pressed into the chair. In reality, the chair is pressing up on you, which you interpret as being pushed down.

LESS than 1, you **FEEL LIGHTER** than usual and can feel as if you are almost lifting out of the chair. This is how you feel when an elevator starts down suddenly.

At a given point on a ride, everyone, regardless of mass, experiences the same force factor.

On a certain ride, a 50 kg girl is being pushed with a force of 1500 Newtons.

(A) What force factor is she experiencing?

If we round **g** off to 10 m/sec² her gravitational force is 500 Newtons.

$$\text{Force factor} = \frac{\text{Force being applied}}{\text{Force due to gravity}} = \frac{1500 \text{ Newtons}}{500 \text{ Newtons}} = 3$$

(B) If her friend weighs 120 pounds, what force (in pounds) is her friend feeling?

They will feel the same force factor. This time, the number given is the person's weight. Her normal (rest) weight is 120 pounds, but she is experiencing a force factor of 3 and is therefore feeling a force of 3 times her normal (rest) weight. The force on her must be 3 x 120 pounds = 360 pounds.

YOUR TURN, SHOW YOUR WORK

An 80-kg boy is on a ride where he is feeling a force of 2000 Newtons.

(A) What force factor is he experiencing?

Force factor = _____

(B) What force is his 500 Newton girl friend feeling?

Force felt = ____ Newtons

If your answers were a force factor of 2.5 and 1250 Newtons, you have it!!

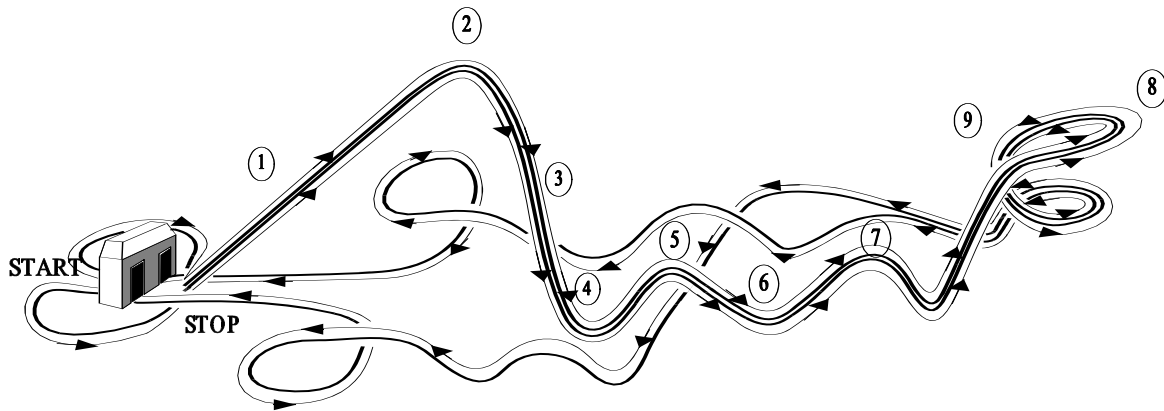

1. Why is the first hill of the American Eagle® the highest?
2. Why is the operator of the American Eagle® NOT concerned about the mass of the passengers?
3. Describe the sensations you experience while riding over and down the “hills”. At which point(s) do you experience a sensation of weightlessness?
4. Why do the heights of successive “hills” decrease as you move from the beginning to the end of the ride?
5. When do you have the greatest speed during the ride?
6. When is your speed the least during the entire ride (not including being at rest at the start and finish)?

7. List the locations of energy that are utilized by the American Eagle®. These locations might be in the gravitational field, the coaster, the track, etc.
8. Why is a roller coaster, such as the American Eagle®, like a simple pendulum?
9. Use the diagram on the previous page and record the following:

_____ Maximum speed	_____ Maximum kinetic energy
_____ Minimum speed	_____ Minimum kinetic energy
_____ Maximum potential energy	_____ Weightless sensation
_____ Minimum potential energy	_____ Heavy sensation
10. Some roller coaster enthusiasts claim the first roller coaster car offers the most thrilling ride; others insist that the last car provide the biggest thrills. Discuss the merits and disadvantage of both positions. Be sure to explain your answers thoroughly based on the physics involved. Show mechanical or electronic data to support your claim.
11. Describe where the American Eagle's® track is banked. Explain the purpose of banking roller coaster track.
12. List as many safety features as you can that are used in the American Eagle®.

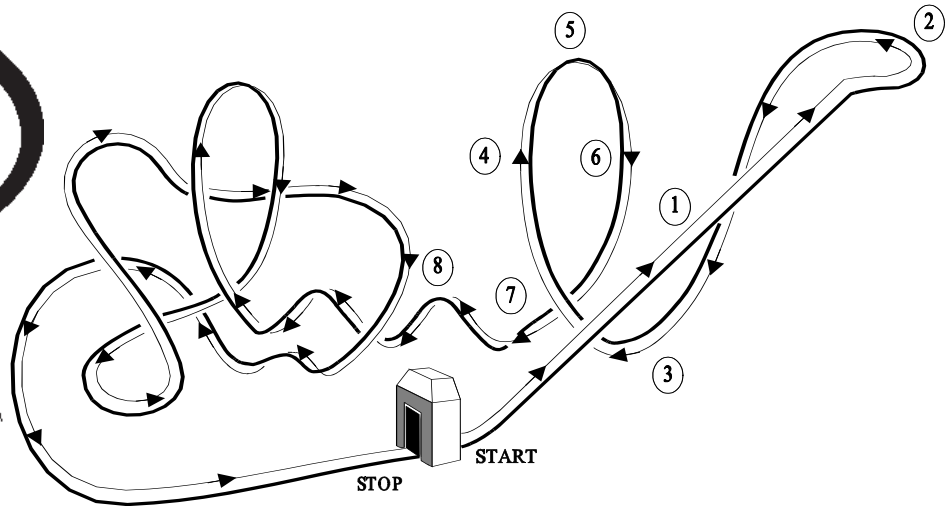

1. Calculate the force due to the track, force due to the chain, and the force down the inclined plane of the track due to gravity for a ride up the high rise.
2. Calculate the minimum horsepower needed to haul one Batman™ train up the high rise.
3. Estimate the speed of the Batman train as it bottoms out right before the first vertical loop.
4. Produce a force diagram for the train in the first vertical loop at the following clock positions: 3, 6, 9, and 12 o'clock. Is the force of the track at 12 o'clock the same magnitude as the force of the track at 6 o'clock? Please explain. Calculate the force of the seat for a 60 kg person at the 3, 9, and 12 o'clock positions.
5. When the train is at the bottom of the first vertical loop, will the structural supporting feet for the vertical loop push up or pull down at point A? Answer the same question for point B. Please support your answers. *(Please use the diagram at the bottom of the next page.)*
6. Compare the average radius of the first vertical loop of Batman to the average radius of the first vertical loop of the Iron Wolf®. Does each vertical loop have the same average radius? Explain any differences. Even though a passenger is riding on the outside of the vertical loop for the Batman ride, does one experience the same sensation for both the Batman and Iron Wolf vertical loops?
7. It has been said that one can easily lose their shoes during this ride. Where would this most likely happen? If you lost your shoes at your predicted location, where would you place a shoe catcher along the ground?

8. Position yourself along the walkway between the first vertical circle and the zero "g" roll section of Batman. Listen to the sound of the train as it travels down the first big hill through the vertical loop and then through the next vertical loop. Is the frequency of the sound due to the train's motion changing pitch? Please explain.

9. From point C to point D, the heart line (the path your heart traces through space) follows a parabolic path. Why didn't the engineers design the track to look exactly like a parabola? *(Please use the diagram at the bottom of this page.)*

10. Total mechanical energy at any one section is gravitational potential energy + kinetic energy at that location. When Batman twists through the zero "g" roll does it possess more kinetic energy than if it were to just glide through without twisting? Please explain your answer.

11. Using the diagram on the previous page, record the location of the following:

<input type="checkbox"/> Maximum speed	<input type="checkbox"/> Maximum kinetic energy
<input type="checkbox"/> Minimum speed	<input type="checkbox"/> Minimum kinetic energy
<input type="checkbox"/> Maximum potential energy	<input type="checkbox"/> Weightless sensation
<input type="checkbox"/> Minimum potential energy	<input type="checkbox"/> Heavy sensation

12. Describe your sensation in terms of forces at each point on the labeled diagram of the track layout at the top of the first page.

Use the drawing to answer questions 5 and 9.

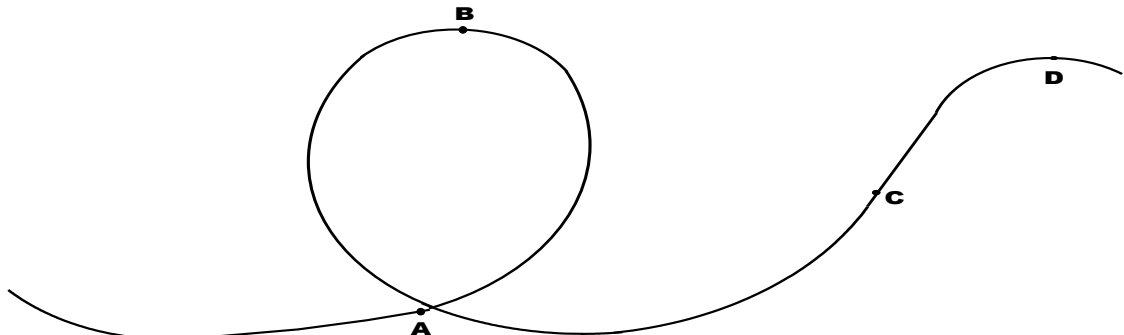

CHUBASCO

1. Can you keep your cup from spinning as the ride turns?
If so, how?
2. What happens as you spin the cup faster?
3. Does the motion of the ride from inside the cup look the same as it does watching it from the side?
4. To spin faster you should spin your cup (clockwise) (counterclockwise).
5. Draw a top view of the path of a non-spinning cup.
6. Do you feel more force on your body if you turn the cup clockwise, counter-clockwise, or let it freewheel? Do accelerometer readings correspond to what you feel?
7. If you do not turn the wheel, does the distribution of bodies (mass) in your cup make any difference in your accelerometer readings? (Yes or No) If yes, what is the difference?
8. What would be the effect if the cups did not sit on the small platform?
9. What is the maximum number of people who can ride Chubasco at one time, or during one cycle?
10. The maximum number of people who can ride Chubasco in one hour is 650. How many complete rides, or cycles, does Chubasco make per hour?
11. How much time does it take to complete one full cycle?

12. **The actual ride lasts 2 minutes, 30 seconds. The rest of the time is used for loading and unloading passengers. How much time does it take to load and unload passengers each cycle?**

13. **The large platform travels at a rate of 4 revolutions per minute. Therefore, the smaller platforms complete four large circles every minute. Calculate the distance the center of mass of the smaller platforms travel each minute.**
(Hint: Find the circumference of the path the small platforms travel. The circumference is equal to the distance one platform travels each revolution. So to find the distance traveled during one minute, or 4 revolutions, multiply the circumference by 4.)

14. **Each of the small platforms travels at a rate of 4 revolutions per minute. Calculate the distance each cup edge travels in one minute.**

15. **Before the ride begins to move, see how fast you can spin the cup. Let one or two people spin the cup as fast as they can. Assign one person as timekeeper. The timekeeper will wait until the spinners get the cup moving at a good speed and begin timing for one minute. This can be done by choosing one large item that can be seen in the distance as a reference point. Then count the number of times you see the reference point. This is the number of revolutions made.**

16. **Each cup has a diameter of 7 feet. Using the speed you just determined, calculate the distance you traveled in one minute.**

Columbia Carousel

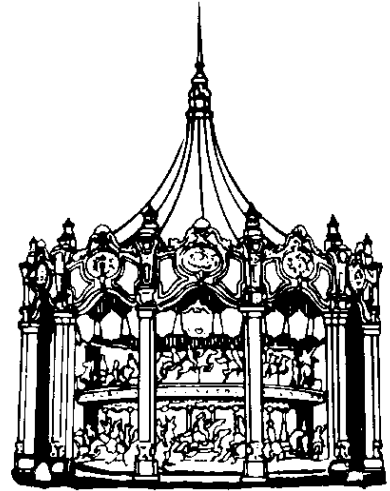

- 0
1. Describe the motion of a passenger on a carousel horse. A sketch may be used.
2. Is a person on a moving carousel horse moving with a constant speed? Explain your answer.
3. Which passengers seem to be moving faster; those on outer horses or those on inner horses?
4. Determine the circumference of the outer ring of horses. Measuring the distance between the support poles of two adjacent horses and multiplying this distance by the total number of spaces between horses may do this.
5. Calculate the linear speed of a passenger on an outer horse by dividing the circumference of the ring by the period of rotation.
6. Repeat questions 4 and 5 for the inner ring of horses.
7. Compare your answers to questions 5 and 6. Did you answer question 3 correctly?
9. Using the value you obtained for the circumference of the outer ring of horses in question 4, calculate the radius of the outer ring.
10. Determine the centripetal acceleration of a passenger on an outer horse using the values you have obtained for the speed and radius.
11. Use your accelerometer to measure the centripetal acceleration while riding a horse on the outer ring. How does this value compare to the computed value obtained in question 10?

DEMON

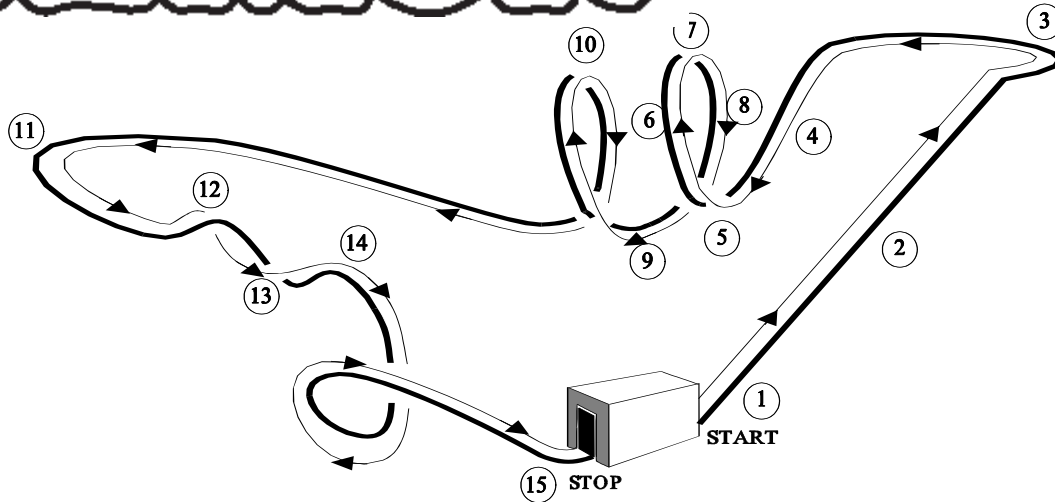

1. Describe the sensations you experience while riding over and down the "hills." At which point(s) do you experience a sensation of weightlessness?
2. Why do the heights of successive "hills" and loops decrease as you move from the beginning to the end of the ride?
3. When do you think you have the greatest speed during the ride?
4. When is your speed the least during the entire ride?
5. List the locations (field, track, train . . .) of energy that are utilized by the Demon.
6. Why is a roller coaster, such as the Demon, like a simple pendulum?
7. Why is it not necessary to carefully monitor the mass of the passengers that board the Demon?
8. What is the height of the initial high rise?
9. What is your speed at the bottom of the high rise, assuming no friction?

10. What would be your speed if you were to fall "freely" from the top to the bottom of the high rise?
11. How much work does the track do for one complete ride? (Assume no friction.)
12. What is your acceleration down the first incline (the high rise)? Express your answer as a fraction of "g".
13. Where is your gravitational potential energy $1/4$, $1/2$, and $3/4$ of the maximum gravitational potential energy at the top of the high rise? Calculate these gravitational potential energy values ($1/4$, $1/2$, $3/4$ of maximum gravitational potential energy) in joules.
14. Produce a graph of kinetic energy, gravitational potential energy and total mechanical energy as a function of the height of the high rise. Assume no frictional forces.
15. Estimate the minimum horsepower required to lift a train of roller coaster cars and passengers to the top of the high rise.
16. Why are the Demon's vertical loops teardrop shaped? How does this type of loop, known as clothoid loop, differ from a circular loop?
17. Some roller coaster enthusiasts claim the first roller coaster car offers the most thrilling ride; others insist that the last car provides the biggest thrills. Discuss the merits and disadvantages of both positions. Be sure to explain your answers thoroughly based on the physics involved.
18. Use the diagram on the previous page and record the location of the following:

_____ Maximum speed	_____ Maximum kinetic energy
_____ Minimum speed	_____ Minimum kinetic energy
_____ Maximum potential energy	_____ Weightless sensation
_____ Minimum potential energy	_____ Heavy sensation



1. Find the maximum height of the car. Find the height of the car when braking begins (HINT: Look for the top of the tallest copper fins along the tower.).
2. Calculate the gravitational potential energy at the top of the ride.
3. Calculate the velocity of the car at the moment braking begins. What ultimately happens to all of the energy of the system?
4. Find the acceleration of the car as it begins its descent. Find the maximum acceleration of the car while braking.
5. Draw position – time, velocity – time, and acceleration – time graphs for one complete cycle.

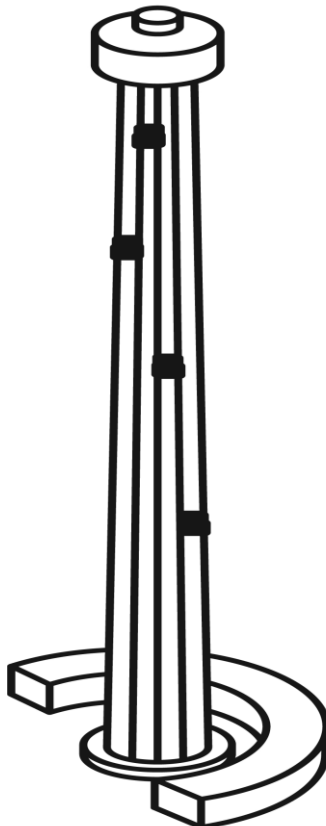

6. Draw force diagrams of the occupants at each of the point indicated in the figure on the next page. For points B and C indicate the forces in each direction of travel.
7. Calculate or measure the magnitude of all forces acting on you at each of the indicated points. For points B and C, separate calculations need to be made for each direction of travel. Assume your mass to be 70 kg.
8. The braking system on this attraction is unique: it is passive and requires no friction. The back of each car has very strong magnets that induce eddy currents in the long copper sheets in the lower portion of the tower. What is the significance of these eddy currents? Why do the copper sheets have occasional slits in them?
9. Carefully observe the motion of the car on the way up. Does the acceleration change when the car leaves the copper sheet region on the tower, and if so, by how much? What would account for this change?
10. This is one of the few rides in amusement parks in which the average stopping force can be found by using the Impulse – Change in Momentum relationship. Calculate the change in momentum during braking. What is the average braking force?

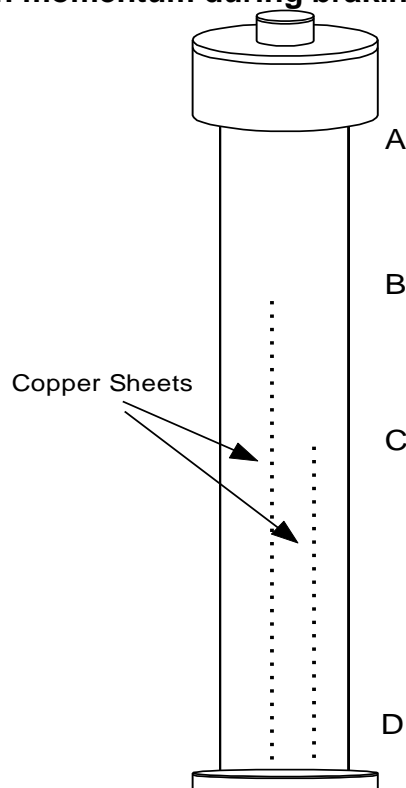

Hometown Fun Machine

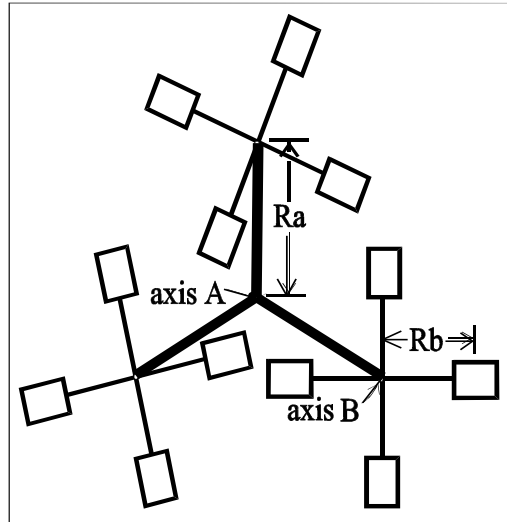

Qualitative Observations

1. As viewed from a stationary position above the Hometown Fun Machine sketch your path during one full revolution.
2. Where along the path is your speed relative to the ground a maximum? minimum?
3. What is the direction of your velocity when your speed is at maximum? at minimum?
4. Where along the path is your acceleration maximum? minimum?
5. What is your position along the path when you feel the greatest force? the least? What are their directions? What is the apparent force called?
6. If someone were watching from a stationary position above the Hometown Fun Machine, they would describe a different force acting of you. What would the direction of this force be? What is this force called?

Quantitative Measurements

Measure the time 't' it takes you to make one full rotation about axis B.

t = _____

Measure the time 'T' it takes axis B to make one full rotation about axis A.

T = _____

Measure or estimate the distance 'r'.

r = _____

Measure or estimate the distance 'R'.

R = _____

7. Using your measurements of t, T, r and R, make a drawing to scale of your path during one full revolution of the Hometown Fun Machine about axis A.

8. Calculate your maximum and minimum speed.

$V_{\max} =$ _____ $V_{\min} =$ _____

9. Calculate the magnitude of your maximum and minimum acceleration.

$a_{\max} =$ _____ $a_{\min} =$ _____

10. Knowing your mass and maximum and minimum accelerations, calculate the maximum and minimum centripetal forces acting you during one revolution.

$F_{\max} =$ _____ $F_{\min} =$ _____

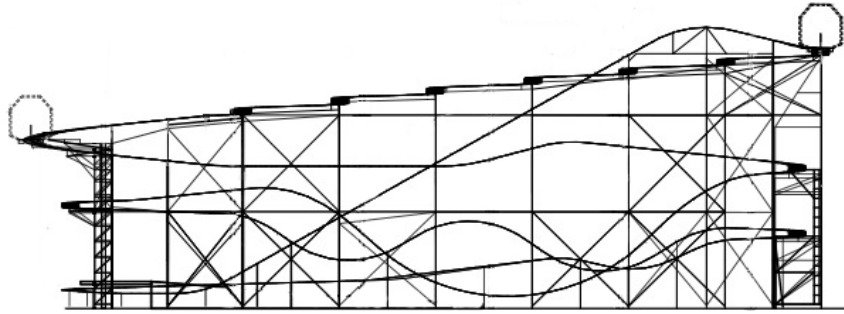

1. Consider the mass and placement of riders in the Dark Knight[®] car. What arrangements of riders would increase the car's rotation? What arrangements of riders would decrease the car's rotation? Justify your answer and check it by riding The Dark Knight[®].
2. There is no braking on the switchback section of the tracks for Dark Knight[®]. Using conservation of energy, what is the expected velocity at the end of one complete set of switchbacks? The start and stop positions of interest are the illustrated cars on the right and left, respectively, in the drawing above. Compare this calculated value with the measured velocity. What is the percent of difference? Where did the energy go? Draw an energy flow diagram and energy bar charts for the selected points on this ride.
3. The Dark Knight[®] has pre-performance and performance sections to the ride. Use acceleration-time graphs to illustrate how these terms apply to the ride.
4. How does the lack of light in The Dark Knight[®] change your perception of the ride? How does the spinning of the car change your perception of the ride?
5. Measure your pulse and respiration when you first get onto the ride and immediately at the end of the performance section of the ride. Were there any significant differences with your reactions compared to others in your laboratory group? NOTE: You may need to take your pulse after the performance section, but before you arrive back at the loading platform.

King Chaos

This ride is a vertical dual axis-turning ride. It has elements of Condor[®] and a fast moving Ferris wheel.

1. Describe your sensations of weight at the following locations of the ride:
 - a. at rest
 - b. moving through the lowest point
 - c. at the highest point
 - d. halfway, going up
 - e. halfway, going down
2. Draw a force diagram for a rider at each of the points in Question 1.
3. Record either electronically or with a spring accelerometer, the acceleration at each point in Question 1. Using a typical rider's mass (yours would be fine), find the force (in the direction of the accelerometer) at each of the specified points.
4. Determine the period of full rotation of the long arm and the short arm of the platform. Is this ride a good example of uniform circular motion? Support your claim.
5. Observe the ride from the side of one of the anchoring towers. Sketch the path taken by a rider during the maximum motion of the ride.
6. What is the hourly capacity of the ride?
7. Describe how this ride would change if the direction of rotation were reversed. Include sensations, and relate them to forces.

Using Electronic Data Collection

8. Find the points of minimum and maximum acceleration. Do these happen at a particular elevation?
9. Determine the vector sum acceleration at each point of the ride.
$$a_{sum} = \sqrt{a_x^2 + a_y^2 + a_z^2}$$
10. Graph the vector sum of the acceleration as a function of time. Compare it to elevation.
11. Apply fast Fourier transform analysis (FFT) to the acceleration data to find the primary frequencies (if any) of the ride.

Loggers Run

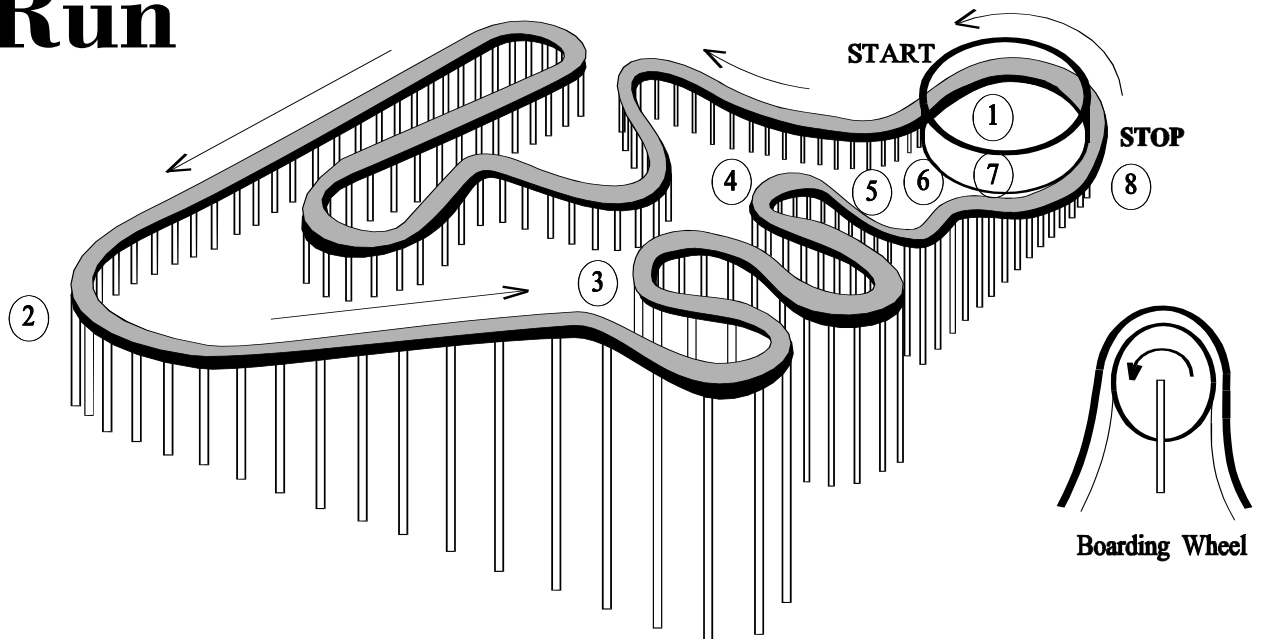

1. Describe your sensations when you first step on the "boarding wheel." For example, describe your acceleration at the instant you step on the wheel.
2. After you have been on the wheel for a few seconds, describe your motion in terms of your velocity and acceleration.
3. What is the relative velocity between you and the boat as you board your boat?
4. Calculate the centripetal acceleration of a person standing on the wheel.
5. Describe the energy transfers that occur to you and your boat between the time you leave the boarding area and the time you start to ascend the incline plane.
6. Determine the minimum amount of work the electric motor must do to lift a loaded boat to the top of the big ramp. Assume no frictional forces are acting.
7. Determine the horsepower of the motor. Assume no friction.
8. Calculate the acceleration of a boat as it slides down the big slide. Express your answer in "g's."
9. Why do passengers lunge ahead when they reach the bottom of big slide?
10. Determine the net work done on a boat and its passengers for one complete trip around the ride.

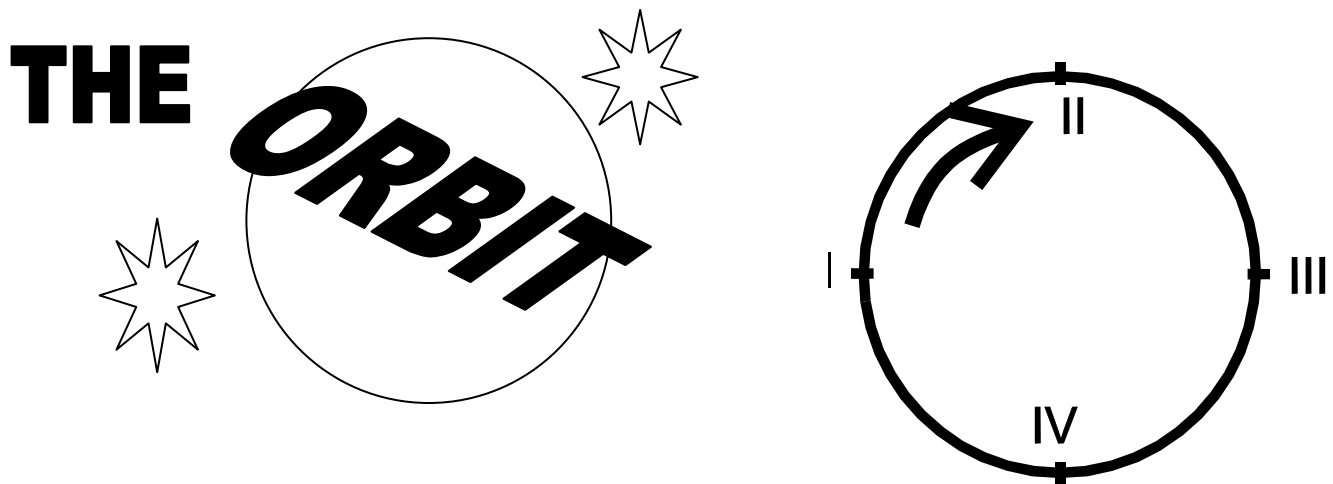

1. Look at two different points on the Orbit. Is the linear speed the same for each point? If your answer is no, under what conditions will the linear speed be the same for each point? If your answer is yes, then what does each point have in common?
2. Estimate the radius of the Orbit. Compute the linear speed of a "car" or seat while the orbit is moving in a vertical circle.
3. Calculate the centripetal acceleration and the force of the seat on a 70 kg person at the top of the vertical circular motion (12 o'clock position).
4. Does the Orbit ever move with uniform circular motion? Please explain your answer.
5. Under what conditions would the force due to the seat become zero for the 12 o'clock (top) vertical position? Calculate the speed of the car necessary to cause the force due to the seat to be zero.
6. Draw a force diagram for a rider at the following clock positions: 6, 9, 12, and 3 o'clock.
7. While the Orbit is moving in a horizontal circle, derive a relationship between angle each seat cabins out from the vertical and the linear speed.

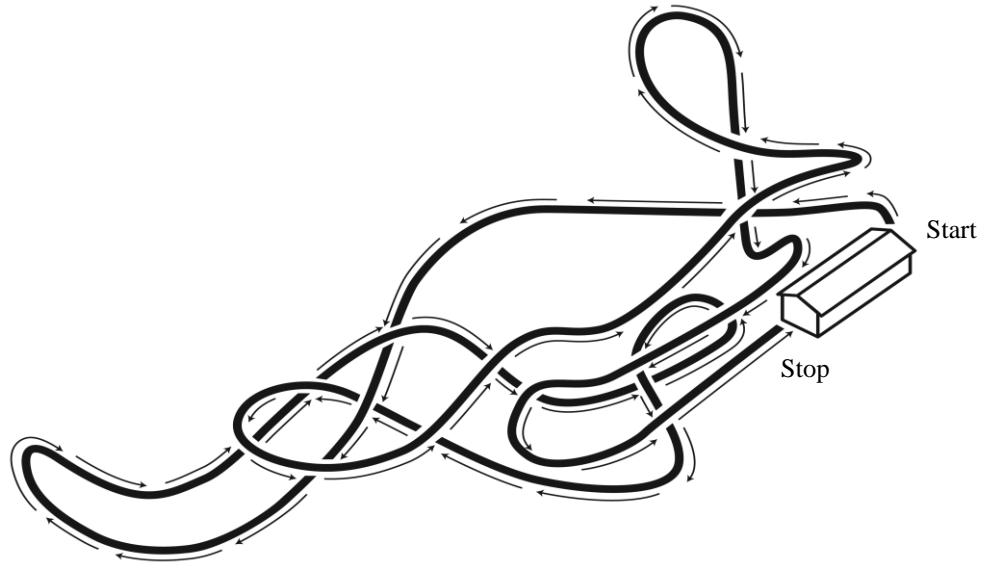

Many of the questions asked on other non-looping roller coasters (American Eagle[®], Viper[®], and Whizzer) may be applied to this ride. The questions below are for use on this ride, and tend to be of a more advanced nature.

The first car has a mass of 1950 kg, and each of the other of cars of the nine-car train has a mass of 1225 kg when empty.

1. The manufacturer of Raging Bull[®], Bolliger and Mabillard, are Swiss. All of their measurements are in metric. The design length of the train is 17000 mm, the width is 2210 mm, and the heart line is 1200 mm above the track. The Urethane[®] road wheels have a diameter of 354 mm. Measure the initial speed of the train at the top of the lift hill and the three succeeding hills.
2. Measure the height of the lift hill, and the next three hills. Draw a bar graph of gravitational potential energy plus kinetic energy, versus the hills. Discuss the significance of the trend of this graph. This is sometimes referred to as the friction profile.
3. Calculate the energy transfer from kinetic energy into thermal energy due to friction from the top of the lift hill to the top of the third successive hill.
4. The exit ramp from the Viper crosses over the tunnel for Raging Bull. Measure the speed of the train entering the tunnel, exiting the tunnel, and the average speed in the tunnel. Please show all of your work, and describe your methods of measurement.
5. The maximum banking angle on the first hill is 55° (see diagram next page).
 - A. Draw a force diagram for the center of mass of the train as it is moving over the maximum-banked part of the curve (the center).
 - B. Is this the optimal banking angle for the speed of the low friction train?

6. Draw energy bar graphs for each of the following seven positions: at the top of the lift hill, 1/3 the way down the lift hill, at the bottom of the lift hill, 1/2 way up to the next hill, and at the tops of the three successive hills. Be sure to include on each graph, quantitatively, total energy, kinetic energy, gravitational potential energy, and thermal energy. You may assume that since the wheel size is small, that the rotational energy is negligible. Write a paragraph discussing the changes in the different energies, and relate it to the total energy.
7. The tunnel at the bottom of the lift hill is 1.83 meters below grade at the base of the lift hill. Face to face distance of the tunnel is 38.7 meters. At the center of the tunnel, the circular section of track is 7.6 meters below the entrance and exit of the tunnel.
- Draw a force diagram of the train at the bottom of the tunnel.
 - Calculate the centripetal force on the train at the bottom of the tunnel.
 - Calculate the normal force (support force) of the track against the center of mass of a fully loaded train.
 - Using your own mass, determine the force you feel on your seat as you round the bottom of the tunnel.
8. The cars roll on Urethane[®] wheels on a metal 1541m track anchored to the ground. The train picks up a sizeable static electrical charge and is periodically discharged. How can this be?

Diagram for question 5

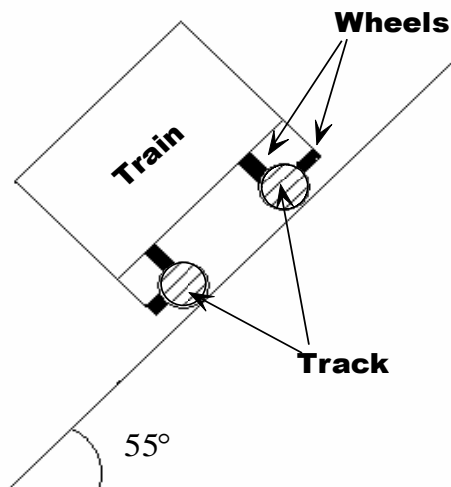



This ride is a combination of a physical pendulum and spinning ride. The analysis of this ride can be very complex and daunting.

Many of the questions for this type of ride can be found in River Rocker[®] and Hometown Fun Machine[®]. The questions below are for use on this ride, and are of a more advanced nature. Most assume electronic data collection with a three-axis accelerometer and barometer.

1. Measure the length of the pendulum arm, radius of the platform palate, and maximum angle from rest the pendulum swings.
2. Draw force diagrams (four total) for a rider at the top and bottom of a swing, with and without rotation. How does the rotation of the platform change the force diagram? Compare these to the force diagram of a rider at rest.
3. Collect the 3-axis accelerometer data as cleanly as possible. Check that the accelerometer sensor is as vertical and horizontal as possible. Using these data, describe in words the motion in each individual direction.
4. Determine the vector sum acceleration at each point of the ride.

$$a_{sum} = \sqrt{a_x^2 + a_y^2 + a_z^2}$$

5. Correlate the largest and smallest acceleration vector sum with points on the swinging motion. This can be done by comparing altitude with the sum. At which points is the ride most and least intense?
6. Apply fast Fourier transform analysis (FFT) to the acceleration data to find the primary frequencies of the ride.
7. Is this a free or driven pendulum ride? Please support your claim by citing examples from your data.

River Rocker

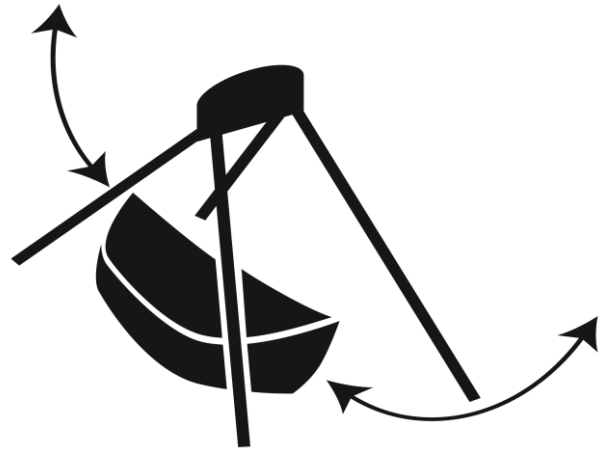

1. Does the position of your seat affect the way you feel on this ride?
2. When are you traveling the fastest? slowest?
3. Describe your sensation of weight:
 - A. at rest
 - B. moving through the lowest point
 - C. at the highest point
 - D. halfway, going up
 - E. halfway, going down
4. Record your vertical accelerometer readings:
 - A. at rest
 - B. moving through the lowest point
 - C. at the highest point
 - D. halfway, going up
 - E. halfway, going down
5. Where did the maximum acceleration occur? Is this point the same for every seat?
6. Is the maximum and minimum accelerometer reading the same for every seat?
7. What happens to the way you feel as the ride swings higher?
8. Do you feel the same swinging forward as you do swinging backward?
9. To feel the lightest, you should sit (closer to) or (farther from) the center of the canoe?
10. When you are the highest above the ground, you are traveling the (slowest) or (fastest)?
11. When you are highest above the ground, you feel the (lightest) or (heaviest)?

19. Determine the radius of the ride.
20. Determine the period of the ride by timing 10 swings.
21. Based on the measured period, is the River Rocker a simple pendulum?
22. Determine the height your seat reaches.
23. Use conservation of energy to determine your gravitational potential energy and kinetic energy when:
 - A. at rest
 - B. moving through the lowest point
 - C. at the highest point
 - D. halfway, going up
 - E. halfway, going down
24. Determine your velocity when:
 - A. at rest
 - B. moving through the lowest point
 - C. at the highest point
 - D. halfway, going up
 - E. halfway, going down
25. Calculate your centripetal acceleration when:
 - A. at rest
 - B. moving through the lowest point
 - C. at the highest point
 - D. halfway, going up
 - E. halfway, going down

Rue Le Dodge

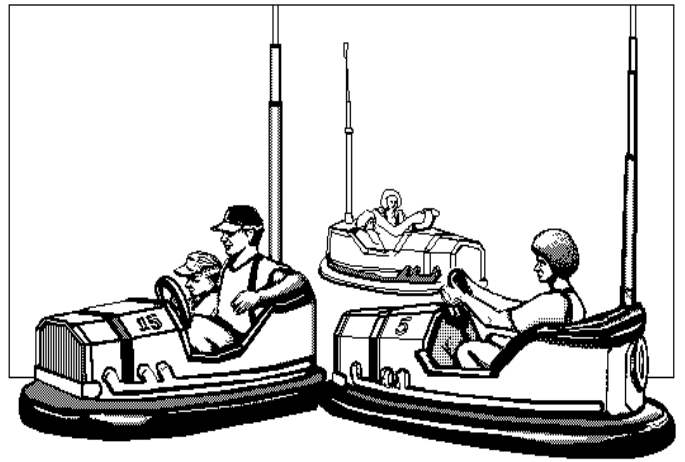

1. Do you smell anything strange inside the Rue Le Dodge pavilion when the cars are operating? Can you determine what the source of this smell is?
2. Each bumper car has a long pole that extends to the ceiling of the pavilion. What is this pole for? How do you know?
3. Describe the complete electrical circuit that supplies electrical energy to one of the cars.
4. In a head on crash with another car or the wall, which way is your body thrown?
5. When you are hit in the rear by another car, which way is your body thrown?
6. When you collide with another car, which type of collision (rear end, front end, or from the side) shakes you up the most? Why do you think this is so?
7. When you collide with another car, does the car that hits you exert a force on you? How do you know?
8. During a collision, is kinetic energy conserved? Explain your answer.
9. Is the total mechanical energy (kinetic and potential) of the bumper cars conserved? Explain your answer.
10. How does the conservation of energy apply to the Rue Le Dodge bumper cars?
11. Would the bumper car collisions be classified as elastic or inelastic?
12. Is the momentum of each bumper car conserved in a collision? Explain your answer.
13. Is the momentum of all cars involved in a collision conserved? Explain your answer.
14. Why do the bumper cars have rubber bumpers? Be sure your answer is "timely"!

Sky Trek Tower

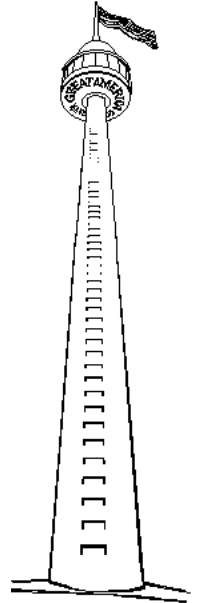

- 1. The cabin is rising. For this motion (please support your answers):**
 - A. Is the upward force of the cable constant or changing?**
 - B. Is the kinetic energy of the elevator constant or changing?**
 - C. Is the gravitational potential energy of the elevator constant or changing?**
 - D. Is the acceleration of the elevator zero, a constant other than zero, or changing?**
 - E. Is the total mechanical energy (kinetic and potential) constant, zero, or changing?**
- 2. The cabin is descending. For this motion please answer questions 1 A through E above.**
- 3. What is the average velocity of the cabin for one round trip?**
- 4. What is the average speed of the cabin for one round trip?**
- 5. What is the average angular velocity of the cabin for one round trip?**
- 6. Find the height of the cabin using triangulation procedures. Estimate the mass of the cabin with passengers. Calculate the gravitational potential energy of the cabin at the top with passengers. Assume the mass of each rider to be 60 kg.**

7. When the cabin reaches the top, it rotates with a constant angular velocity. Assume an object is released inside the cab at arms length. Describe the motion of the dropped object with respect to a person inside the cab. Describe the motion of the dropped object with respect to a person fixed to the earth's frame of reference. If the object was dropped out over the edge of the cabin, describe the dropped objects motion as seen by an observer in the rotating cab and by an observer in the earth's frame of reference.
8. Raindrops are dripping from the bottom of the cabin while the cabin is moving upward. Describe the motion of the raindrops with respect to an observer fixed to the earth's frame of reference.
9. Assume you are sitting on a bathroom scale while riding the cabin. Describe during what part of the ride the bathroom scale would read:
 - A. higher than your true weight
 - B. less than your true weight
 - C. equal to your true weight
10. Describe the motion of a bouncing tennis ball inside the cabin while the cabin is ascending to the top.
11. What advantages are there to designing the cabin like an elevator with a counterweight?
12. When the cabin reaches the top, which component of the velocity vector becomes zero?

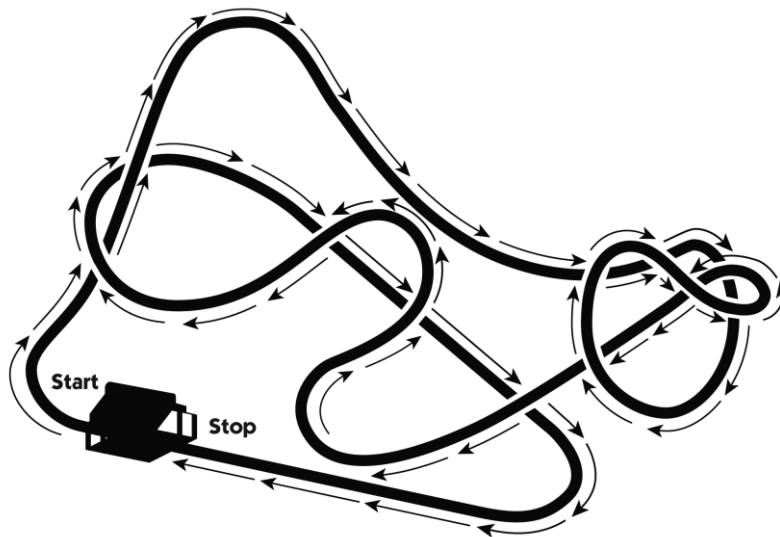

Due to the nature of SUPERMAN: ULTIMATE FLIGHT, this ride is difficult to manage data taking devices on. Let us take a look at this ride from an engineering standpoint.

Before you ride:

1. Notice that the wheels are not all the same.
Why do you think that different materials would be used to make the wheels? What reasons, based on physics, explain these differences?
2. While waiting in line, record the time it takes the train to complete its trip. Time several trips to get an average time.

Time #1 _____ s Time #2 _____ s Time #3 _____ s

Average time of travel _____ s

After you ride:

3. Where along the ride did you experience the largest g-acceleration? What part of you experiences the greatest pressure?
4. Draw a free-body diagram for this location on the ride.
5. SUPERMAN-ULTIMATE FLIGHT[®] contains 2,798 feet of track. Using the average time of travel measured above; calculate the roller coaster's average velocity.

$$v = \underline{\hspace{2cm}} \text{ ft/s} = \underline{\hspace{2cm}} \text{ m/s}$$

6. If the ride time were cut in half, how would this change the average velocity of the coaster?
7. How would this change in average velocity affect the amount of g-acceleration that you feel during the portion of the ride that you mentioned in question 2?
8. In terms of safety measures, what concerns do the engineers have to address when designing and building a ride of this nature? Do you think that the different materials that make up the wheels of this ride come into play? How?
9. How much of a role does the mass of the passengers play in the average velocity of the ride? (Hint: try to estimate the mass of passengers on a full train vs. the mass of the train itself – would there be a huge difference?)
10. Another way of asking question 9 might be...do you notice a significant difference in the time it takes for the train to return to the loading dock with each ride? What are the chances that the mass of passengers in a full train is exactly the same with each load?

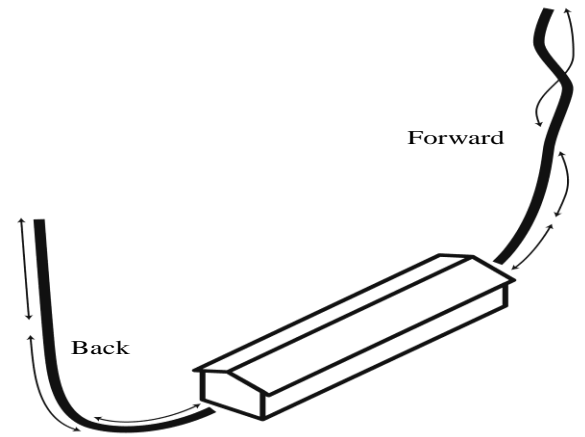

Many of the questions asked on the other non-looping roller coasters (Raging Bull[®], Viper[®], American Eagle[®], and Whizzer) may be applied to this ride. The questions below are for specific use on this ride, and tend to be of a more advanced nature.

1. Explain the propulsion and braking devices for this ride.
2. Compare the initial forward acceleration out of the station with the final acceleration stopping as it is coming into the station. Which acceleration needed more electric current for the linear induction motors?
3. What is the electric current demand necessary to lift a passenger in the first seat up the spiral tower? Do not consider the train or other riders for this calculation. The electric potential for this ride is 400 volts.
4. Using an electronic accelerometer, determine the maximum linear velocity.
5. Using an electronic accelerometer, determine the centripetal acceleration ascending each arm. Compare the magnitudes of the accelerations for going both forward and backward.
6. Using an electronic accelerometer, determine the average centripetal acceleration in the forward spiral.
7. Using a barometer, compare the maximum heights on each segment of the ride. Account for any differences.
8. Does seat position in the train affect the results for question 7? Explain your findings.
9. From the information in question 8, compare the gravitational potential energy of a passenger with the kinetic energy of the passenger using the information in question 4. How much of the mechanical energy is transferred to thermal energy when the train is at the top of the first tower?
10. Compare the acceleration going up the back tower with the acceleration going down the back tower. Explain your findings in terms of Newton's Laws.

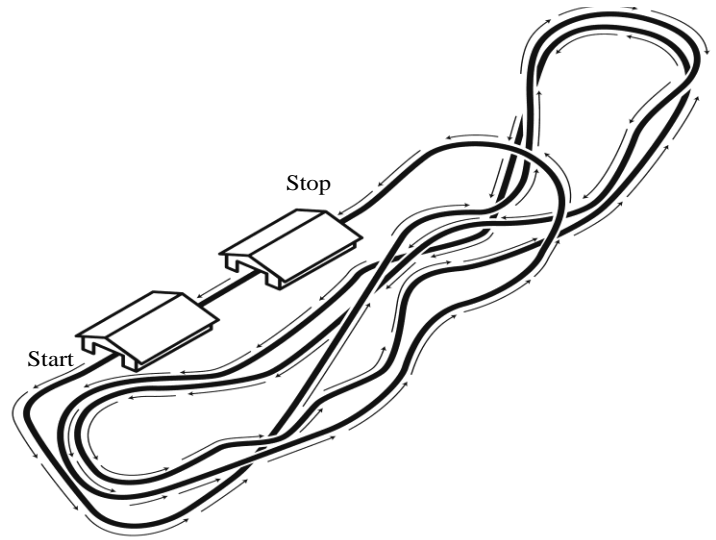

1. Where was the highest hill on the ride? Why is it there?
2. Did you feel lateral forces while on the ride (i.e., were you thrown side to side in the train car)? If so, what forces caused that feeling?
3. Where on the ride did you feel you were going the fastest?
4. Where on the ride did you feel you were lifted off your seat? How did the ride cause this feeling?
5. At which points on the ride did you experience maximum and minimum accelerations? Explain why.
6. Calculate the gravitational potential energy of the train and riders at the top of the first hill.
$$\text{GPE} = mgh$$
7. Determine the speed of the train at the bottom of the first hill using the length of the train and the time it takes the train to pass a point at the bottom of the first hill.
$$V = x/t$$

8. Use the gravitational potential energy calculated in question 6 to determine the speed at the bottom of the first hill. Compare this speed to the one calculated in question 7.

$$\text{GPE} = \text{KE} = \frac{1}{2}mv^2$$

9. Use the speed in question 7 to calculate the kinetic energy of the train at the bottom of the first hill.

$$\text{KE} = \frac{1}{2}mv^2$$

10. Determine the energy loss due to friction, using the gravitational potential energy calculated in question 6 and the kinetic energy calculated in question 9.

Whirligig

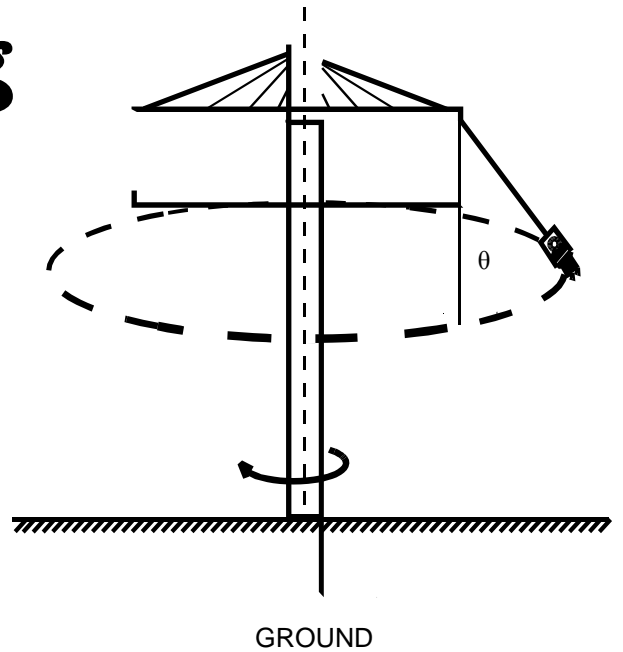

1. Measure the radius of the ride (outer swings) at rest.
2. Measure the radius of the ride (outer swings) at top speed.
3. Measure the length of one chain.
4. What causes the swings to move out as the ride accelerates?
5. Draw a force diagram for a rider at rest.
6. Draw a force diagram for a rider on a swing at top speed.
7. Calculate the a_c at the largest radius.
8. Verify the predictions of question 5 and question 6 with actual sensations as you ride the ride. Give your comparisons.

Whizzer

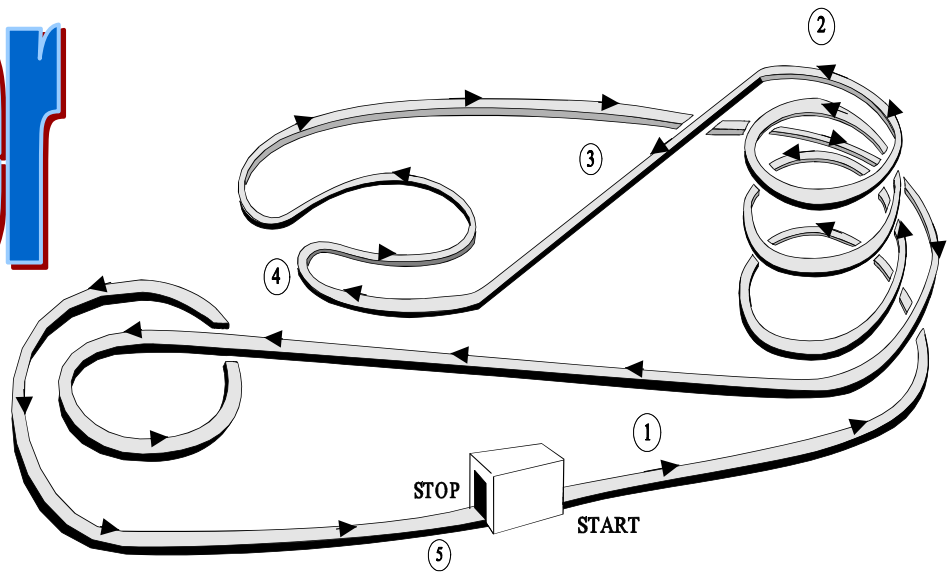

1. At which point(s) during the ride is force exerted on the train of cars by:
 - A. an electric motor
 - B. gravity
 - C. friction
2. Describe places on the ride where:
 - A. gravitational potential energy is being transferred into kinetic energy
 - B. kinetic energy is being transferred into gravitational potential energy
 - C. potential energy remains constant
 - D. kinetic energy is decreasing without an increase in gravitational potential energy
3. Determine the maximum height of the Whizzer.
4. Determine the gravitational potential energy of a train of cars and passengers when they are at their maximum height.
5. How much work must the electric motor do in order to lift a full train to the top of the high rise on the Whizzer? Assume negligible friction.
6. Determine the horsepower of the electric motor used to lift the train to the top of the high rise.
7. Explain why the spiraling track of the Whizzer becomes progressively more banked from top to bottom.

8. Where during the ride is the inward, or centripetal, force exerted by the track on the cars the
- A. least
 - B. greatest
 - C. zero

9. Determine the net work done on you for the entire trip around the Whizzer.

10. Determine the total amount of work done by friction on you during the entire trip.

11. Use the diagram on the previous page and record the location of the following:

_____ Maximum speed

_____ Maximum kinetic energy

_____ Minimum speed

_____ Minimum kinetic energy

_____ Maximum potential energy

_____ Weightless sensation

_____ Minimum potential energy

_____ Heavy sensation

AMUSEMENT PARK PHYSICS MIND BOGGLERS

1. List the rides that represent uniform circular motion.
2. List the rides that represent vertical circular motion that may not necessarily be uniform circular motion.
3. Why can't the formula $4\pi^2 r / T^2$ be used for non-uniform vertical circular motion?
4. Please list any velocity-dependent forces. Is gravity a velocity-dependent force? Please support your answer.
5. Why do amusement park operators first run the rides empty?
6. Define a conservative force. Is the force of gravity a conservative force? Is the force of friction a conservative force?
7. In your opinion, should amusement park rides be designed for speed or acceleration?
8. Fill out the following chart. Please indicate whether the listed quantity is a vector or scalar. Also, give the correct SI unit for the listed quantity. Please draw the correct symbol for each quantity.

QUANTITY	TYPE	UNIT	SYMBOL
Work			
Power			
Acceleration			
Force of Friction			
Potential Energy			
Kinetic Energy			
Speed			
Mass			
Height			
Time			
Angular Velocity			
Total Mechanical Energy			
Revolutions			
Angle Theta			

MIND BOGGLERS-Continued

9. Why is a simple pendulum like a roller coaster ride?
10. Please design your own roller coaster. Label regions of maximum and minimum kinetic energy. Also, label regions of maximum and minimum gravitational potential energy.
11. Define in your own words kinetic and gravitational potential energy. Can an object have gravitational potential energy but not kinetic energy? Give an example at Six Flags Great America. Can an object have kinetic energy but not gravitational potential energy? Give an example at Six Flags Great America. Can an object have zero gravitational potential energy and zero kinetic energy? Give an example at Six Flags Great America today.
12. Can a roller coaster have an eastward velocity and a westward acceleration? Can roller coaster have an eastward velocity and a downward acceleration?
13. What rides at Six Flags Great America essentially start with nearly all gravitational potential energy and very little kinetic energy? What rides at Six Flags Great America start with kinetic energy and very little gravitational potential energy?
14. Give an example of a ride at Six Flags Great America where the speed is constant but the acceleration is zero.
15. Do your sense organs feel velocity or acceleration? Is the human body an accelerometer? Please explain.
16. Cite four examples at Six Flags Great America where each of Newton's three laws are illustrated.
17. What is the mean free path for your bumper car ride?
18. In your opinion, where is the center of mass of Six Flags Great America?
19. Cite an example at Six Flags Great America where the following cases are true: The angle between a velocity vector and the acceleration vector is 180 degrees; $180 > 0 > 90$ degrees; 90 degrees; zero degrees.
20. Does the phrase, 3 "g's," refer to a force or to an acceleration? Please Explain.

GREAT AMERICA PHYSICS SCAVENGER HUNT

Can you find an example of each of the following quantities, entities, or concepts in the park?

<i>QUANTITIES, ENTITIES, CONCEPTS</i>	<i>EXAMPLE</i>
Constant Speed	
Constant Velocity	
Acceleration	
Circular Motion	
Centripetal Force	
Centripetal Acceleration	
Inertia	
Net Force	
Equilibrium	
Frictional Force	
Fictitious Force	
Inertia Frame of Reference	
Non-inertial Frame of Reference	
Action-Reaction forces	
Newton's First Law	
Kinetic Energy	
Potential Energy	
Work	
Conservative Force	
Non-Conservative Force	
Sensation of Weightlessness	
Doppler Effect	
Plane Mirror	
Concave Mirror	
Convex Mirror	
Refraction	
Standing Wave	
Polarization	
Strobe Light	
Free Fall	